

HTC2500 Theory of Operation

HTC2500 is designed using RTOS (Real Time Operating System). Our approach in favor of using RTOS in this design was to capitalize on functionality and created reusable modules. Design it self was not complicated demanding usage of RTOS. But we decided use it to enhance functionality and have some fun in trivial design. Another advantage of using RTOS is making software reusable and easier to manage. Basic operation of RTOS is simple. It allows simultaneous execution of several tasks (almost) and integration of reusable software modules. In this design we separated hardware functional blocks in to separated tasks and actually modeled real hardware functionality in those tasks.

We have following tasks running in our RTOS:

1. Real Time Clock.
2. Display Mode Control
3. Display Driver
4. Keyboard Driver

Real Time Clock:

This task keeps real time clock. It updates second counter every second and when second counter reaches sixty it clears second counter and increments minute counter. If minute counter reaches sixty it clears and hour counter is incremented by one. When hour counter reaches thirteen, it clears. Each counter has two-digit binary coded decimal output. This task runs ones every second.

Display Mode Control:

Since we are using four digit display and need to display more than six digits of information we decided to use this task to manage what information to display based on user control. By utilizing this task we can switch between different modes of HTC2500 operations for example "Normal Operation", "Set Hour Mode", "Set Minute Mode" etc. This task runs 256 times every second. Since we have four digits we refresh our display 64 times per second to insure crisp display or in other words we have 64Hz display refresh rate. This task also manages colon LED control. Colon LED is turned on if second counter is even. This makes colon LED to be turned on every two seconds for one second.

Display Driver:

Display driver manages four digit seven segment LED display. We used multiplexed display driving method to minimize interconnections between HTC2500 and LED display. This also minimizes external component count and lowers overall design cost. In our design we used common cathode LED display. In this task we convert four digit decimal coded (supplied by Display Mode Control task) to seven segment coded output. This output drives seven segments of LED display (A, B, C, D, E, F, G) and column LED. By putting one on one of this segments and driving zero to corresponding cathode of selected digit we can arbitrary turn on (light up) that segment.

Keyboard Driver:

Keyboard driver is responsible for scanning keyboard inputs (SET, MODE and Power OK). This task is run about every 125mS. It also scans for any conditions when key is held down for more than two seconds. This task is also responsible for de-bouncing those inputs. Set and mode inputs are scanned for key-up event exempt when you hold those keys for more than two seconds. It means keyboard generates valid output when you release a key.

Our decision to use RTOS...

helped us a lot to manage those tasks and produced readable and usable code for our future developments.

Obstacles we run during development were:

1. Usage of 32768Hz crystal. We decided to use this crystal for its wide availability and low cost. But using this crystal made our life harder when we end up having only 8192 instructions (Microchip micro-controllers divide input clock by 4) to play with. This was an exercise well worth its efforts.
2. Refreshing Display on time. In order to refresh display on time we put this task in the middle of our RTOS (it became our main task) and other tasks were written around it.

Unique features of HTC2500 are:

1. Low power consumption during power down mode. In this mode HTC2500 is powered with backup battery and it consumes less than 0.12mA current. This low current consumption eases backup power selection. For example if we use 9V alkaline battery for backup power it will last for more than three months (depending on design).
2. Key inputs. Those inputs are internally de-bounced and have high input resistance. Those two factors widen our options of selecting input switches or in other words those inputs can tolerate low quality input signals. For example we can use push buttons, membrane switches or conductive rubber switches to control those inputs.
3. Single chip construction with minimal external components.

Construction of clock using HTC2500

In this section we will build AC powered Simple clock using HTC2500. For backup power we will use 9V battery. In our clock design we used Panasonic LED display but other displays could be used as well.

Clock Schematic

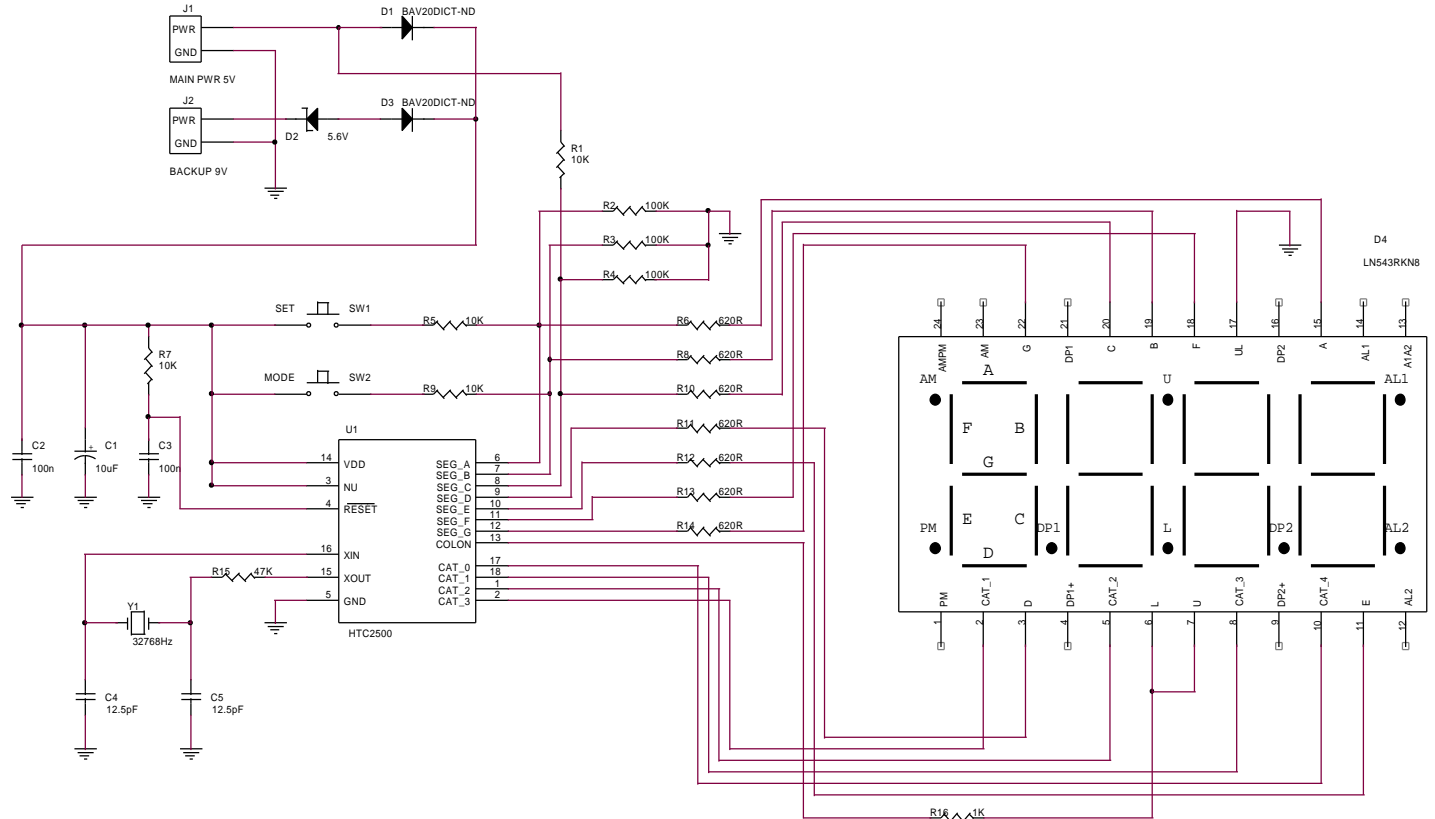

Part List For Simple Clock

Item	Description	QTY	Reference	Part number	Available from...
1	10uF Low leakage electrolytic capacitor	1	C1	P5134-ND	Digikey
2	100n ceramic axial capacitor	2	C2, C3	1210PHCT-ND	Digikey
3	12.5pF ceramic disc capacitors	2	C5, C4	P4016A-ND	Digikey
4	Small signal diode	2	D1, D3	BAV20DICT-ND	Digikey
5	5.6V zener diode	1	D2	1N5232BDICT-ND	Digikey
6	Common cathode seven segment 4 digit multiplexed display.	1	D4	P454-ND	Digikey
7	5V DC connector	1	J1	CP2503-ND	Digikey
8	9V battery snap cable	1	J2	BS12I-ND	Digikey
9	10K 1/8Wt resistor	4	R1, R5, R7, R9	10KEBK-ND	Digikey
10	47K 1/8Wt resistor	1	R15	47KEBK-ND	Digikey
11	100K 1/8Wt resistor	3	R2, R3, R4	100KEBK-ND	Digikey
12	620R 1/8Wt resistor	7	R6, R8, R10, R11, R12, R13, R14	620EBK-ND	Digikey
13	1K 1/8Wt resistor	1	R16	1KEBK-ND	Digikey
14	Switch	2	SW1, SW2	EVQPAC-04M	Digikey
15	Digital clock controller	1	U1	HTC2500	High Tech Chips, Inc.
16	32768Hz crystal	1	Y1	SE3202-ND	Digikey

Web site for Digikey could be found at www.digikey.com.

Web site for High Tech Chips, Inc. could be found at www.hightechips.com.

Part Selection...

In this design we selected readily available and low cost parts. All parts are available through Digikey except HTC2500. We will go into detail on our selection of parts and will discuss several changes and operating characteristics of design.

Resistors...

All resistors in this design are selected to be through hole type to simplify bread-boarding of this project. Cost of design and production could be reduced further if surface mount resistor networks are used to replace those resistors. R15 value is chosen as per Y1 crystal manufacturer specifications (we use Epson crystal in our design).

Capacitors...

We used several capacitors in this design and they have different requirements. C4 and C5 are chosen as per Y1 crystal manufacturer specifications (we use Epson crystal in our design). C1 should be low leakage type to insure minimal discharge of battery during main power failure.

Display...

We used Panasonic display in our design because of its high brightness at low current (200uCd at 5mA). It is possible to construct Big Digit display by using several LED's per segment. In that case we need to drive this display using external driver. HTC2500 can drive up to two LED's in series per segment or in other words it can drive led with forward voltage of 4V.

Backup battery...

We chose 9V battery in our design for backup power because of its wide availability. During power down mode (when main power is down) measurements were taken on our prototype and they were below 70uA (current consumption from battery). This is low enough to make this battery last for several months without losing time. Alternative of using backup battery could be a capacitor. If we used dual layer 1F(one farad available from Digikey) capacitor for backup energy storage it would last for 9 hours.

Power consumption...

Measured during normal operation using our prototype was at 20mA. This was the main reason we did not specify part number for power supply. Most wall mount power supplies are rated for 200mA and above. Taking low power consumption of design into account it is easy to construct transformer-less power supply for this design. Design of transformer-less power supply lays out of scope of this application and we do not recommend designing one if you don't have previous experience. We recommend using T202-ND (4.5V at 300mA) wall mount transformer, available from Digikey, to power this design.